

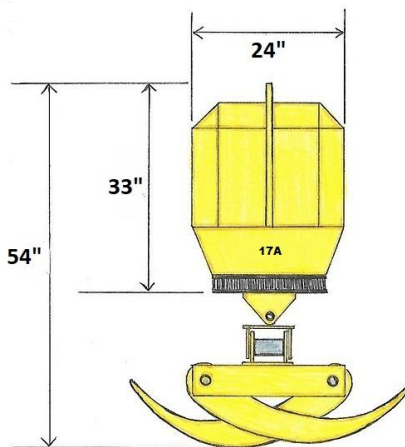

756 Carrier Street East Gate, Kamloops, British Columbia, V2H1G2 Email: gatergrapples@shaw.ca Phone: 1-866-374-7088

MODEL 17A

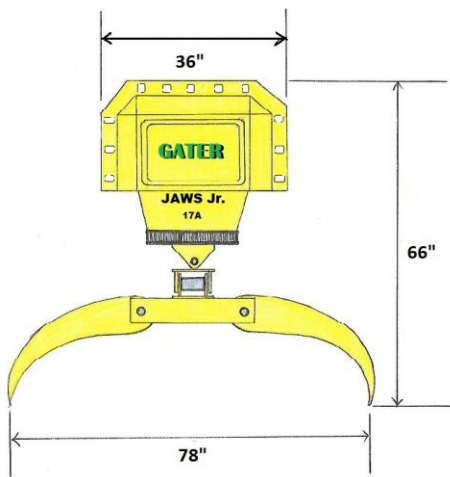

Model 17A

JAWS Junior

Introducing the newest member of the "Jaws" line of high lead grapples.

Specifications:

- 6 hp Kubota diesel engine
- Tier 4 compliant – no DEF
- Light weight 1000lbs approximately
- Jaws open to 6 ½ feet (78 inches)
- Jaws close to 4 inches
- Load sense hydraulics
- 5 gallon per minute hydraulic piston pump
- Continuous rotation
- 1000ft radio controls
- 2 transmitters and 1 receiver standard
- 20,000 lbs capacity ring bearing

OPTIONS

- 9 hp Kubota engine
- 3000 foot radios
- 1500 foot real time camera system
- 3000 foot real time camera system